



# Instruction Manual

**Scrubmaster B70 (7061.10/.15/.20/.22)**

## Introduction

### **Preface**

Dear customer, It is our desire that the good characteristics of the Scrubmaster B70 should justify the confidence you demonstrated by making this purchase.

Prior to the first drive, carefully read the chapter "Safety Information" as well, in order to ensure you a safe working with the machine.

Your own safety, as well as the safety of others, depends to a great extent on how the vehicle is moved and operated.

Therefore, carefully read and understand this operation and maintenance manual prior to the first drive.

The manual provides valuable information about operation, service and maintenance. The warning symbols as used in this manual identifies items relevant to safety. Please observe the safety provisions (see chapter "Safety Information").

Your authorised Hako dealer will be pleased to answer further questions regarding the vehicle or the operation and maintenance manual.

Please be advised explicitly that we cannot accept any legal issues out of the contents of this manual.

If repair work has to be performed make sure that only genuine spare parts are used; only genuine spare parts may guarantee a dependable machine. We reserve the right for technical improvement..

Valid as of: April 2014

**Hako GmbH**  
**D-23843 Bad Oldesloe**  
**Hamburger Str. 209-239**  
**Telefon ++49 (04531) 8060**

### **Proper use**

The machine is a vacuum scrubbing machine for wet cleaning of hard-surfaced floors. Using the machine beyond this scope of application will be deemed improper use; The manufacturer cannot be held liable for consequential damages; the user alone bears the risk.

The term of proper use also includes operation, maintenance and repair work to be performed in compliance with the manufacturer's specifications.

The Scrubmaster B70 may be used by persons only that are familiar with the machine and aware of possible hazards involved.

The applicable Accident Prevention Regulations and further regulations in vigour concerning aspects of safety and working medicine will have to be complied with.

If modifications to the machine are made in absence of the manufacturer's prior consent, the latter cannot be held liable for damage resulting from such unauthorized modification.

## Introduction

### **Notes on warranty**

The terms of the sales contract apply. Damages are not subject to warranty if they are due to non-compliance with the maintenance and service provisions. The maintenance work has to be performed by an authorized Minuteman service center and confirmed in the "Maintenance certificate" which is the warranty document.

The following is excluded from warranty: fuses, natural wear, damages caused by overload, inexpert handling and unauthorized modification of the machine. Moreover, any claim for warranty cannot be accepted if damages of the machine are caused by fitting parts or accessories without Minuteman's prior and explicit consent or by non-compliance with the maintenance instructions.

### **Acceptance of the machine**

Upon arrival, check machine for possible damages in transit. For refund of such damage, have the Deutsche Bahn AG or your freight forwarder confirm such damage. Mail notification and waybill to:

**Hako GmbH**  
**Hamburger Strasse 209-239**  
**23843 Bad Oldesloe**

## Table of Content

	<b>Introduction</b> . . . . .	<b>2</b>	3.1.1	Brush Head . . . . .	12	5.5.2	Empty Clear Water Tank . . .	29
	Preface . . . . .	2	3.1.2	Clear Water Tank . . . . .	12	5.5.3	Clean Clear Water Filter . . .	29
	Proper use . . . . .	2	3.1.3	Squeegee . . . . .	13	5.6	Soiled Water Tank . . . . .	30
	Notes on warranty . . . . .	3	3.1.4	Soiled Water Tank . . . . .	13	5.6.1	Empty Soiled Water Tank . .	31
	Acceptance of the machine . .	3	3.1.5	Travel Drive . . . . .	13	5.6.2	Clean Soiled Water Tank . .	31
<b>1</b>	<b>Safety information</b> . . . . .	<b>5</b>	3.1.6	Batteries and Charger . . . .	13	5.6.3	Clean Suction Filter . . . . .	31
1.1	Safety and Warning Symbols .	5	3.1.7	Options . . . . .	13	5.7	Plate brush head . . . . .	32
1.2	General Provisions . . . . .	6	3.2	Operating and Indicating Ele- ments . . . . .	14	5.7.1	Clean Brushes . . . . .	32
1.3	Provisions for Operation . . .	6	3.2.1	Operating Panel . . . . .	14	5.7.2	Change Brushes . . . . .	32
1.4	Maintenance instructions . . .	7	3.2.2	At the machine . . . . .	16	5.7.3	Change Deflector Roller . . .	32
1.5	Specific Hazards . . . . .	7				5.7.4	Change Sealing Strip . . . . .	32
1.6	Information for Protection of En- vironment . . . . .	8	<b>4</b>	<b>Technical Data</b> . . . . .	<b>18</b>	5.8	Squeegee . . . . .	33
1.7	Labels at the Machine . . . . .	9	<b>5</b>	<b>Maintenance and Care</b> . . . .	<b>20</b>	5.8.1	Cleaning the Squeegee . . . .	33
<b>2</b>	<b>First Operation</b> . . . . .	<b>10</b>	5.1	Hako System Maintenance . .	20	5.8.2	Changing the Sealing Strips .	33
2.1	Instruction . . . . .	10	5.2	Maintenance document . . . .	21	5.8.3	Adjusting the Sealing Strips .	34
2.2	Initial charging procedure . . .	10	5.3	Maintenance Schedule . . . . .	22			
2.3	Before Taking into Operation	10	5.4	Battery Systems . . . . .	26			
2.4	Start Machine . . . . .	10	5.4.1	Charge Batteries . . . . .	27			
2.5	Operation . . . . .	11	5.4.2	Low Discharge Signal sender (LDS) . . . . .	27			
2.6	Stop Machine . . . . .	11	5.4.3	Maintenance of Drive Batteries 27				
2.7	After Work . . . . .	11	5.4.4	Remove Batteries . . . . .	27			
2.8	Transport rides . . . . .	11	5.4.5	Install Batteries . . . . .	27			
2.9	Tie-down points . . . . .	11	5.4.6	Disposal of Batteries . . . . .	27			
<b>3</b>	<b>Operation</b> . . . . .	<b>12</b>	5.5	Clear Water Tank . . . . .	28			
3.1	Method of operation . . . . .	12	5.5.1	Fill Clear Water Tank . . . . .	29			



### **EC-Declaration of Conformity 37**

## Safety information

### 1 Safety information

#### 1.1 Safety and Warning Symbols

All paragraphs in this manual referring to your personal safety, the safety of your machine and the environment protection are attributed one of the following warning symbols:

Symbol	Hazardous for ...	Description
Safety Provisions 	persons and goods	Safety Provisions in dangerous situation caused by misuse inaccurate adherence of instructions or prescribed work routine.
CAUTION 	the machine	important information on handling the machine in order to maintain operability.
Ecological hazard 	the environment	due to use of substances representing an inherent danger to health of environment

## Safety information

### 1.2 General Provisions

- Apart from the provisions contained in this instruction manual, the general safety provisions and the accident prevention regulations as imposed by law have to be complied with.
- Before taking your machine into operation, carefully read the instruction manual as well as other separate instructions for accessories or attached implements and comply with all points mentioned there during work.
- Persons being trained by qualified Hako technicians only are authorised to operate, service and repair the machine.
- You are advised to thoroughly study the safety instructions since precise knowledge only helps avoiding errors during operation of the machine and thus guarantee faultless usage of the machine.
- The operating instructions have to be at hand at the place of use of the machine, and therefore have to be kept readily available at the machine.
- When selling or letting the machine for rent, hand out these documents

to the new owner/operator and have the transfer certified!

- The warning and instruction plates attached to the machine contain valuable advice about safe operation. Immediately replace incomplete or illegible labels.
- As far as safety standards are concerned, spare have to equal genuine spare parts!

### 1.3 Provisions for Operation

- Before first operation of the machine, fully charge the battery with an initial charging procedure and comply with the operating instructions of the charger as well as with those of the battery manufacturer. Hako cannot be held liable for damages resulting from the fact that the initial charging has not or insufficiently been done.
- Before taking into operation, check the machine for operational safety! Immediately remedy malfunctions!
- It is indispensable for the operator to get acquainted with all attached implements and controls as well as with their function before operation begins. Once you have started to work, no time will be left to do so!

- When working with the machine use firm and skid proof shoes.
- The machine may be used only on such surfaces clearly specified by the owner or his authorised representative.
- When working with the machine take notice of third persons, especially children.
- Start riding immediately after brush head has lowered otherwise the brush might leave traces on the ground. Lift the brush head before riding over obstacles (doorsteps).
- Only fold open empty soiled water tank
- Use only cleaning agents suitable for automatic machines (low-foaming) and comply with the instructions for use, disposal and with the warning information specified by the cleaning agent's manufacturer.
- The machine is not designed for collecting hazardous, inflammable or explosive dusts or substances.
- Usage of the machine in explosive areas is prohibited.
- Pull the switching key to avoid unauthorized use of the machine.
- Before transport of the machine, lift

## Safety information

the squeegee and the brush head. Adapt driving habit to local conditions.

- The machine may be used only for operation on plane areas with a maximum inclination of up to 2 %.

### 1.4 Maintenance instructions

- The daily and weekly maintenance and repair task must be performed by a qualified operator. For any maintenance and repair work beyond please contact your local Hako service centre.
- Observe the maintenance activities and intervals set out in the instruction manual.
- Maintenance and repair work may be carried out only by means of appropriate tools.
- Have the machine checked for safe condition in the sense of the Accident Prevention Regulation by an expert at regular intervals (recommendation: at least once yearly) as well as after modifications or repair.
- Spare parts have to equal the technical requirements as specified by the manufacturer! Genuine spare parts guarantee compliance with these re-

quirements.

- Stop engine before proceeding to inspection and maintenance work.
- To prevent the machine from being used by unauthorized persons, the control key must be removed.
- When performing work at the electrical system, be sure to remove the battery plug.
- Make sure to protect the soiled water tank against accidental closing or tilting down before working in the area of a lifted tank lid.
- Do not clean the electrical parts by means of high-pressure cleaning equipment.
- The use of aggressive detergents is not admitted.
- Let the machine dry after cleaning e.g. for weekend.
- The machine may be taken into operation after all protective devices have been fitted and positioned.

### 1.5 Specific Hazards

#### Electric system

- Only use genuine fuses with prescribed connecting load.
- In case of malfunction of the electric system, immediately shutdown ma-

chine and remedy.

- Qualified personnel only is authorized to proceed to works at the electrical equipment and only according to electro-technical rules.
- Inspect/check the electrical equipment of the machine at regular intervals. Immediately remedy defects such e.g. loose connections or scorched cables.

#### Battery

- Respect the operating instructions of the battery manufacturer.
- Handling and changes of the batteries may take place only by maintenance staff.
- Never place metal objects or tools on batteries - short-circuit hazard!
- Due to alteration of the centre of gravity, only use batteries as released and at the prescribed position only.
- Provide for sufficient ventilation of areas where batteries are charged. – Explosion hazard!
- Refer to safety provisions in supplement 88-60-2556 - Information on drive batteries.

## Safety information

### 1.6 Information for Protection of Environment

- For safe use of substances inheriting a danger to health and environment specific knowledge is required.
- Observe the legal directives and local regulations for disposal of detergents, see Water Management Act.
- Used batteries labelled as recyclable contain reusable economic goods. According to the crossed dustbin label these batteries must not be added to the normal waste. Provide for agreement with the Hako contract dealer on return and disposal according to § 8 BattV.



## Safety information

### 1.7 Labels at the Machine

The following safety and information labels are legibly attached to the machine. Replace missing or illegible labels immediately.

Hako nameplate (Fig. 1/1)

# Hako

Machine identification number (Fig. 1/2)

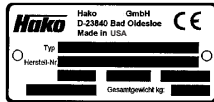

Soiled water drain hose (Fig. 1/3)

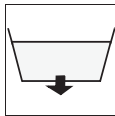

A = Read and observe the instruction manual (Fig. 1/2)

B = Maximum inclination of 2 % (Fig. 1/2)

C = Do not clean the machine by means of high-pressure cleaning equipment (Fig. 1/2)

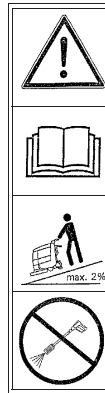

A

B

C

Inflation pressure (Fig. 1/4)

4,5 bar



Fig.1

# First Operation

## 2 First Operation

### 2.1 Instruction

Instruction is required before first operation. First instruction into handling of the machine must be held by a qualified person sent by your local Hako contract dealer. Your Hako dealer will be informed by the manufacturer upon delivery of the vehicle and will contact you to make a date for instruction.

### 2.2 Initial charging procedure



Before first operation of the machine, fully charge the battery with an initial charging procedure and comply with the operating instructions of the charger as well as with those of the battery manufacturer. Hako cannot be held liable for damages resulting from the fact that the initial charging has not or insufficiently been done.

### 2.3 Before Taking into Operation

Proceed to the following inspections before taking the machine into operation:

1. Check parking site for signs of leakage. Hoses, lines and tanks must be

free from any leakage or damage.

2. Install brushes and squeegee, see maintenance chapter.
3. Install batteries and connect battery plug, see maintenance chapter.
4. Check battery charge and proceed to re-charging of batteries if required. Generally proceed to initial charging before first operation of the machine.
5. Empty soiled water tank and clean it if required, see maintenance chapter.
6. Re-fill clear water tank and add cleaning agent according to the manufacturer's recommendations.



Use only cleaning agents suitable for automatic machines (low-foaming) and comply with the instructions for use, disposal and with the warning information specified by the cleaning agent's manufacturer.

### 2.4 Start Machine



Before start of the machine, set accelerator level to neutral position. Should the accelerator lever be out of neutral position and machine be switched on, an error message occurs.

Proceed to the following to set the machine into operating mode:

- Disconnect mains plug of the charger from outlet and fasten to holder if require.
- Switch on machine by actuation of key switch from position (0) to position (1).

## First Operation

### 2.5 Operation

1. Switch on the machine.
2. Use lever (Fig. 4/4) to lower squeegee. Suction turbine switches on automatically.
3. Use regulator (Fig. 4/3) to adjust clear water amount.
4. Use pedal (Fig. 4/10) to lower brush head. Clear water supply switches on automatically.
5. Use accelerator lever (Fig. 3/1) to adjust work speed and direction.



Start moving machine immediately after lowering of the brush head, otherwise the brushes leave traces on the floor. Lift-out squeegee before changing to reverse ride and lift-out brush head before passing over dormers and more.

### 2.6 Stop Machine

If release the accelerator lever, this returns automatically into the neutral position. The machine stops. Protect the machine against unintentional movements or against being inadvertently started.

### 2.7 After Work

1. Ride machine to suitable site for maintenance.
2. Stop machine, lift squeegee and brush head and pull key switch.
3. Empty and clean soiled water tank.



Observe the legal directives and local regulations for disposal of detergents, see Water Management Act.

4. Check clear water filter.
  5. Check seals and suction hose.
  6. Check operating media levels, function and setting.
  7. Charge batteries.
  8. Clean the machine.
- Empty the clear water tank before shutting down the machine for a longer time.



Do not clean the electrical parts by means of high-pressure cleaning equipment.

### 2.8 Transport rides

For transport rides to the place of use of the machine, switch it on, lift-out squeegee and brush head and actuate the accelerator switch according to the desired direction of travel.

### 2.9 Tie-down points

In case of transport on a vehicle or trailer, the machine has to be protected against rolling off. Tie the machine down firmly by lashing it to the front with the eye bolts (Fig. 2/1) and to the rear with the chassis (Fig. 2/2).

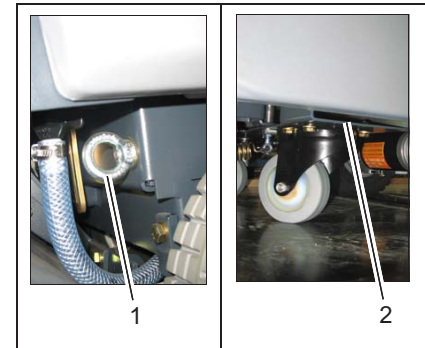

Fig.2

## 3 Operation

### 3.1 Method of operation

#### General

The Scrubmaster B70 is a vacuum scrubbing machine for wet cleaning of hard-surfaced floors.

#### 3.1.1 Brush Head

Lower brush head (Fig. 3/1) via pedal before scrubbing. The brushes rotate and water supply switches on automatically. With the accelerator lever in neutral position (machines stopped) brushes and water supply switch off automatically.

#### 3.1.2 Clear Water Tank

Fill the clear water tank (Fig. 3/2) after folding up the opening. The clear water tank holds 90 litres and the filling level can be followed optically (through transparent hose). Regulation of water amount is available via adjustment handle.



Fig.3

## Operation

### 3.1.3 Squeegee

The movable squeegee (Fig. 3/3) consists of the squeegee lift-out, the suction turbine and sealing strips. The soiled water is wiped from the floor by means of sealing strips. Squeegee is lowered via hand lever. Simultaneously, the suction turbine switches on. The suction turbine works independent of direction of travel and even if the machine stops. Second actuation of the hand lever lifts the squeegee up again and suction turbine is automatically switched off with a delay of 15 seconds.

### 3.1.4 Soiled Water Tank

The soiled water is taken from squeegee to the soiled water tank (Fig. 3/4) by suction turbine and suction hose. For cleaning and collecting water at places where access is difficult, the machine is equipped with handheld suction hose.

### 3.1.5 Travel Drive

The machine features a continuous travel drive (Fig. 3/5). The electronic travel drive control realises modification of travel speed, direction as well as dynamic braking.

### 3.1.6 Batteries and Charger

The machine is equipped with maintenance-free 105 Ah batteries (Fig. 3/6), an automatic charger unit (Fig. 3/7) and a low discharge signal sender (LDS) for protection against low discharge. Information on drive batteries, see leaflet 88-60-2556.

### 3.1.7 Options

- Dosage system and floater unit for automatic filling
- Extraction hose including suction pipe, joint nozzle and wet suction nozzle
- Mop holder and tool-box for cleaning utensils
- Privat-Label for additional labels.
- Scrubbing tool



Accessories such as brushes, rollers, pads, pad holder with centerlock and sealing strips you find in our spare parts catalogue in the Internet under [www.hako.com](http://www.hako.com)

## Operation

### 3.2 Operating and Indicating Elements

#### 3.2.1 Operating Panel

- 1 Display
- 2 Key switch
- 3 Battery charge indication
- 4 LDS indicator
- 5 Symbol brush drive
- 6 Symbol suction turbine drive
- 7 Hourmeter
- 8 Service indicator

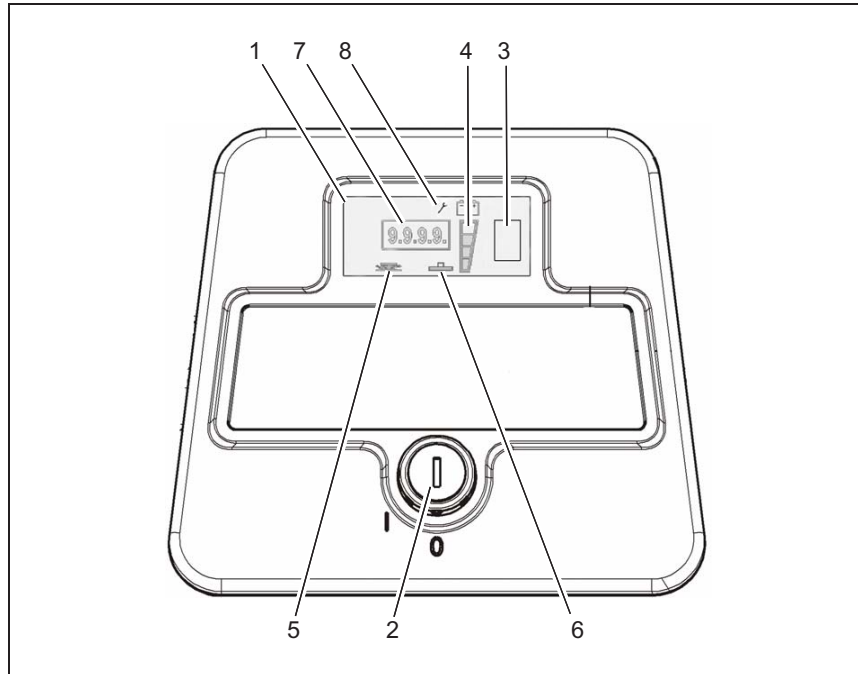

Fig.4

## Operation

### Display (Fig. 4/1)

This panel allows centralized monitoring of functions and detection of all available operating modes.



The key switch turns the electrical system on and off.



Pull the switching key to avoid unauthorized use of the machine.

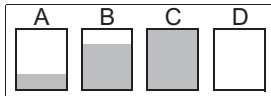

### Battery charge indication (Fig. 4/3)

Battery charge indication appears on the panel during the charging procedure and shows the current charge condition of batteries during the procedure.

The following symbols appear:

Battery symbol A < charge of 20 %

Battery symbol B = charge of 80 %

Battery symbol C = charge of 100 %

Battery symbol D (flashes) = error



### LDS indicator (Fig. 4/4)

Upon switching on, the LDS indication is output on the panel to show the current battery charge condition during operation. Additional information see chapter maintenance.



### Symbol brush drive (Fig. 4/5)

This symbol appears when brush drive is switched on.



### Symbol suction turbine drive (Fig. 4/6)

This symbol appears when suction turbine drive is switched on.

1.1.1.1

### Hourmeter (Fig. 4/7)

Upon switching on, the hourmeter briefly displays the software version and the last error code. Then the current operating hour level is shown.



### Service indicator (Fig. 4/8)

The service indicator lights after occurrence of a system error and cleaning or riding procedure is interrupted. In addition to the service indicator, a 4-digit code is displayed on the hourmeter.

## Operation

### 3.2.2 At the machine

- 1 Accelerator lever
- 2 Opening of clear water tank
- 3 Clear water hand valve
- 4 Hand lever for squeegee lift-out
- 5 Clear water filter
- 6 Soiled water drain hose
- 7 Clear water drain hose (clear water level indication)
- 8 Brush ejector
- 9 Power connection charger unit
- 10 Lever brush head

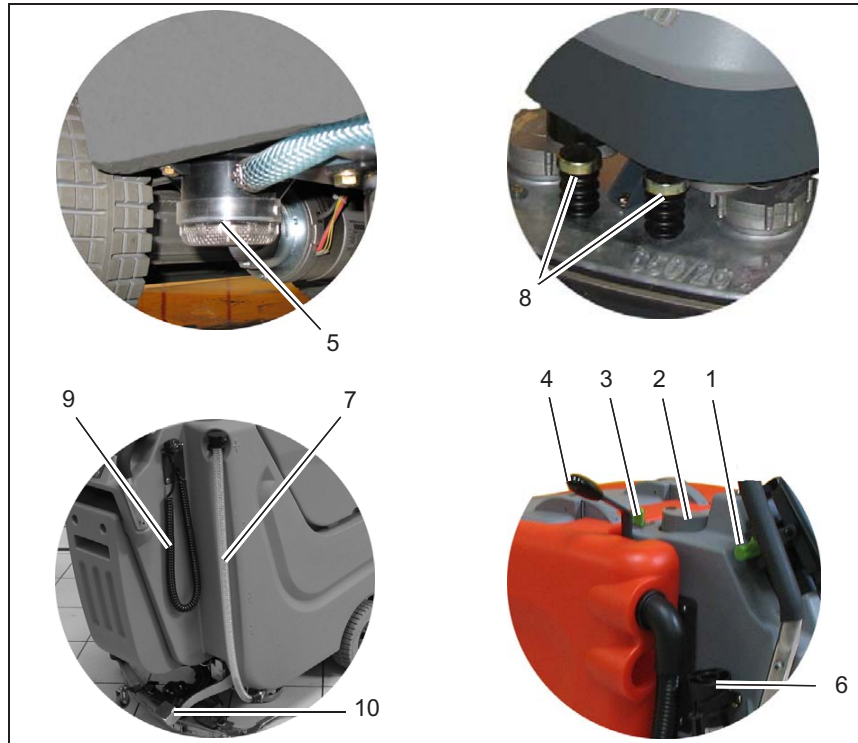

Fig.5



## Operation

### **Accelerator lever (Fig. 5/1)**

With the machine being switched on, the accelerator lever allows continuous regulation of speed. If pulled to maximum position, maximum speed is attained. Reduce speed by taking the lever slowly back. If released, the lever automatically returns into neutral position and the machine stops (deadman function).



Protect the machine against rolling off before leaving it unattended. Before switching the machine on again, make sure that the accelerator lever is in neutral position.

### **Opening of clear water tank (Fig. 5/2)**

The clear water tank is filled after folding up the opening.

### **Clear water hand valve (Fig. 5/3)**

Brush head water supply is regulated by hand valve. The water mount regulation is between 0.l/min and 3.3 l/min.

### **Hand lever for squeegee lift-out (Fig. 5/4)**

Use the hand lever to lift and lower the squeegee. This will deactivate or activate the suction turbine.

### **Clear water filter (Fig. 5/5)**

While clear water flows from tank to brush head, it is cleaned by the filter element.

### **Soiled water drain hose (Fig. 5/6)**

This hose allows draining the collected soiled water from the tank.

### **Clear water drain hose (Fig. 5/7)**

This hose allows draining the clear water tank.

### **Brush ejector (Fig. 5/8)**

The brush ejector makes brush removal fast and easy.

### **Power connection (Fig. 5/9)**

The power connection supplies the charger unit with power.

### **Pedal brush head (Fig. 5/10)**

Use this pedal to lift and lower the brush head.

## Technical Data

### 4 Technical Data

Machine length	cm	151
Machine height	cm	111
Machine width without Squeegee	cm	68
Machine width with Squeegee	cm	95
Working width	cm	65
Squeegee width	cm	95
Surface performance theoretical	m <sup>2</sup> /h	3250
Service voltage	V	24
Nominal power drive motor	W	300
Nominal power suction motor	W	520
Nominal power brush motor	W	2x720
Number of brushes	Qty.	2
Diameter of brushes	cm	33
Work ride	km/h	5,0
Clean water tank	Liter	70
Soiled water tank	Liter	75
Weight without Batteries	kg	177
Weight with water and Batteries	kg	325

## Technical Data

<p><b>Noise emission</b></p> <p>The sound pressure level measured under maximum conditions of use (LwA) according to DIN EN 60335-2-72 amounts to:</p> <p>The sound pressure level measured (at the ear of the driver) under normal conditions of use (LpA) according to DIN EN 60335-2-72 amounts to:</p> <p>Measurement inaccuracy (KpA):</p>	<p>dB (A)</p> <p>dB (A)</p> <p>dB (A)</p>	<p>82</p> <p>67</p> <p>1,6</p>
<p><b>Vibration</b></p> <p>The frequency weighted acceleration measured according to DIN EN ISO 5349 which have an effect upon the upper limbs (hand-arm-system) amounts under normal working conditions:</p>	<p>m/s<sup>2</sup></p>	<p>&lt; 2,5</p>

### 5 Maintenance and Care

#### General



Before proceeding to maintenance and care work you are advised to read and comply with the Safety Information chapter!

Compliance with the recommended maintenance works will give you the certitude of always having a reliable machine at disposition.

Daily or weekly maintenance and repair works may be executed by the driver/operator having been trained accordingly. Further Hako system maintenance works have to be executed by qualified personnel only. Please contact your local Hako Service Centre or Hako contract dealer. We cannot be held liable for damages resulting from non-compliance with these instructions.

Please indicate the machine's serial number with any enquiry or spare part order, see paragraph 1.7 - Nameplate.

#### 5.1 Hako System Maintenance

The Hako System Maintenance:

- guarantees reliable operability of the Hako machines (preventive maintenance)

•

- minimizes operating costs, repair costs and maintenance costs
- ensures long service life and operability of the machine

The Hako System Maintenance is structured in separate modules and determines specific technical works to be executed as well as the intervals for such maintenance works. For any specific maintenance type, the replacement parts are determined and listed in spare part kits.

#### **Hako System Maintenance K:**

To be performed by the customer in accordance to the maintenance and care instructions contained in the operating instructions (daily or weekly). The driver/operator will be instructed upon delivery of the machine.

#### **Hako System Maintenance I :**

(every 125 hours of operation)

To be performed by qualified personnel of authorised Hako Service Centre in accordance with the machine-specific system maintenance including spare part kit.

#### **Hako System Maintenance II:**

(every 250 hours of operation)

To be performed by qualified personnel

of authorised Hako Service Centre in accordance with the machine-specific system maintenance including spare part kit.

#### **Hako-System Maintenance S:**

(every 500 hours of operation safety check)

To be performed by qualified personnel of authorised Hako Service Centre in accordance with the machine-specific system maintenance including spare part kit. Execution of all safety-relevant inspections according to UVV-BGV-TÜV-VDE as prescribed by law.

# Maintenance and Care

## 5.2 Maintenance document

<p><b>Handing over</b></p> <p>Upgrade Test drive Handing over to the customer Instruction carried out on: at _____ operatin hours</p>	<p><b>Hako-System-Maintenance I</b> 125 operating hours Workshop stamp</p> <p>carried out on: at _____ operatin hours</p>	<p><b>Hako-System-Maintenance II</b> 250 operating hours Workshop stamp</p> <p>carried out on: at _____ operatin hours</p>	<p><b>Hako-System-Maintenance I</b> 375 operating hours Workshop stamp</p> <p>carried out on: at _____ operatin hours</p>
<p><b>Hako-System-Maintenance S</b> 500 operating hours Workshop stamp</p> <p>carried out on: at _____ operatin hours</p>	<p><b>Hako-System-Maintenance I</b> 625 operating hours Workshop stamp</p> <p>carried out on: at _____ operatin hours</p>	<p><b>Hako-System-Maintenance II</b> 750 operating hours Workshop stamp</p> <p>carried out on: at _____ operatin hours</p>	<p><b>Hako-System-Maintenance I</b> 875 operating hours Workshop stamp</p> <p>carried out on: at _____ operatin hours</p>
<p><b>Hako-System-Maintenance S</b> 1000 operating hours Workshop stamp</p> <p>carried out on: at _____ operatin hours</p>	<p><b>Hako-System-Maintenance I</b> 1125 operating hours Workshop stamp</p> <p>carried out on: at _____ operatin hours</p>	<p><b>Hako-System-Maintenance II</b> 1250 operating hours Workshop stamp</p> <p>carried out on: at _____ operatin hours</p>	<p><b>Hako-System-Maintenance I</b> 1375 operating hours Workshop stamp</p> <p>carried out on: at _____ operatin hours</p>

## Maintenance and Care

### 5.3 Maintenance Schedule Hako-System Maintenance Customer

The daily and weekly maintenance intervals are to be performed by the customer/operator.

To be performed	Interval	
	daily	weekly
Fill clear water tank and proceed to chemical agent dosage	o	
Charge batteries	o	
Check brush head and clean if required	o	
Check squeegee and clean if required	o	
Clean tank lid sealing of the soiled water tank	o	
Empty soiled water tank. Clean soiled water tank and suction filter	o	
Check brushes/pads and replace if required		o
Clean suction hose of soiled water tank		o
Check squeegee sealing strips and eventually turn round or replace		o
Clean drain hose of clear water tank		o
Check clear water supply to brushes and clean if required		o
Check water filter and clean if required		o
Test drive and function test		o

## Maintenance and Care

### Hako-System Maintenance I

The following maintenance works are to be performed by an authorised Hako Service workshop.

To be performed	Interval
	every 125 hours of operation
Check battery charger	o
Check tank lid sealing of the soiled water tank and replace if required	o
Check drain hose of the soiled water tank and replace if required	o
Grease joints at the brush lift-out	o
Check wheel fixing screws and tighten (32 Nm) if required	o
Check condition of tyres	o
Grease joints at the squeegee holder	o
Test drive and function test	o

## Maintenance and Care

### Hako-System Maintenance II

The following maintenance works are to be performed by an authorised Hako Service workshop.

To be performed	Interval
	every 250 hours of operation
Perform maintenance works according to Hako-System Maintenance I	o
Inspect steering rollers for tread damages and bearing slackness and replace if required	o
Check drain hose of the soiled water tank and replace if required	o
Check deflector roller of the brush head and replace if required	o
Check suction hose for tight fitting and damages and replace if required	o
Check supporting wheel of the squeegee and replace if required	o
Test drive and function test	o



## Maintenance and Care

### Hako-System Maintenance S (Safety check)

The following maintenance works are to be performed by an authorised Hako Service workshop at least once yearly.

To be performed	Interval
	every 500 hours of operation
Perform maintenance works according to Hako-System Maintenance II	o
Clean travel drive motor from carbon dust and check carbon brushes for smooth operation and wearing and replace carbon brushes if required	o
Clean brush motors from carbon dust and check carbon brushes for smooth operation and wearing and replace carbon brushes if required	o
Test drive and function test	o

## 5.4 Battery Systems

- 1 LDS display
- 2 Charger indicator
- 3 Charger
- 4 Mains cable charger
- 5 Battery plug
- 6 Batteries
- 7 Soiled water tank
- 8 Support
- 9 Wiring diagram



Handling and changes of the batteries may take place only by maintenance staff.

During operation, the LSD indicator displays the battery charge status. When the batteries are empty, the battery icon flashes and an acoustic warning signal is issued. The machine functions are restricted. Drive to a charging station immediately.

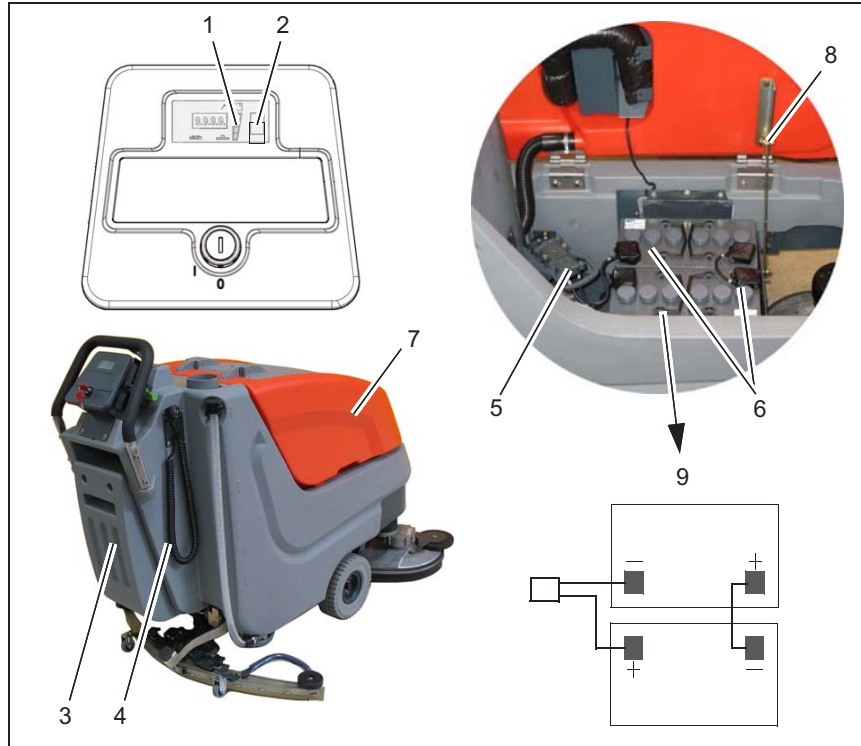

Fig.6

## Maintenance and Care

### 5.4.1 Charge Batteries

Use the integrated battery charger (Fig. 6/3) to charge batteries. Proceed to connection of the charger by means of the mains cable (Fig. 6/4) with safety plug. Charging batteries is recommended if at least one bar of the LDS display has extinguished after operation of the machine. On this behalf you are requested to observe the operating instructions of the charger 88-60-2723 as well as the operating instructions of the battery manufacturer.



Proceed to proper initial charging of the used batteries before first operation of the machine. Hako cannot be held liable for battery damages resulting from non-execution of initial charging.



Provide for sufficient ventilation of areas where batteries are charged. – Explosion hazard!

### 5.4.2 Low Discharge Signal sender (LDS)

The machine has been equipped with a charge indicator to preclude the batteries from low discharge. This low discharge signal sender has been integrated into the electronics. If other batteries are used, re-adjustment of the low discharge signal sender is required.



Only Hako contract workshops are authorised to proceed to adjustment of the low discharge signal sender.

### 5.4.3 Maintenance of Drive Batteries

Refer to operating instructions 88-60-2556 for information on care of drive batteries.

### 5.4.4 Remove Batteries

1. Park machine on level ground.
2. Switch off machine by key switch.
3. Open empty soiled water tank (Fig. 6/7) and secure by support (Fig. 6/8).
4. Disconnect battery plug (Fig. 6/5).
5. Disconnect battery connection cables.
6. Remove batteries.

### 5.4.5 Install Batteries



Due to alteration of the centre of gravity, only use batteries as released and at the prescribed position only.

1. Switch off machine by key switch.
2. Open empty soiled water tank (Fig. 6/7) and secure by support (Fig. 6/8).
3. Place batteries into trough according to figure.
4. Connect battery poles and enclosed connecting cables according to wiring diagram (Fig. 6/9). Provide for tight fitting and grease poles.

### 5.4.6 Disposal of Batteries

Used batteries labelled by the recycling sign contain re-usable substances. According to the labelling by crossed dustbin, such batteries must not be added to normal household waste. Contact your local Hako contract partner for return and recycling according to § 8 BattV!

## Maintenance and Care

### 5.5 Fresh Water Tank

- 1 Fresh water tank
- 2 Marker
- 3 Fill level hose
- 4 Fresh water filter
- 5 Tank lid
- 6 Wing bolt
- 7 Clamping plate
- 8 Lid
- 9 Operating button
- 10 Water connection
- 11 Indicator knob

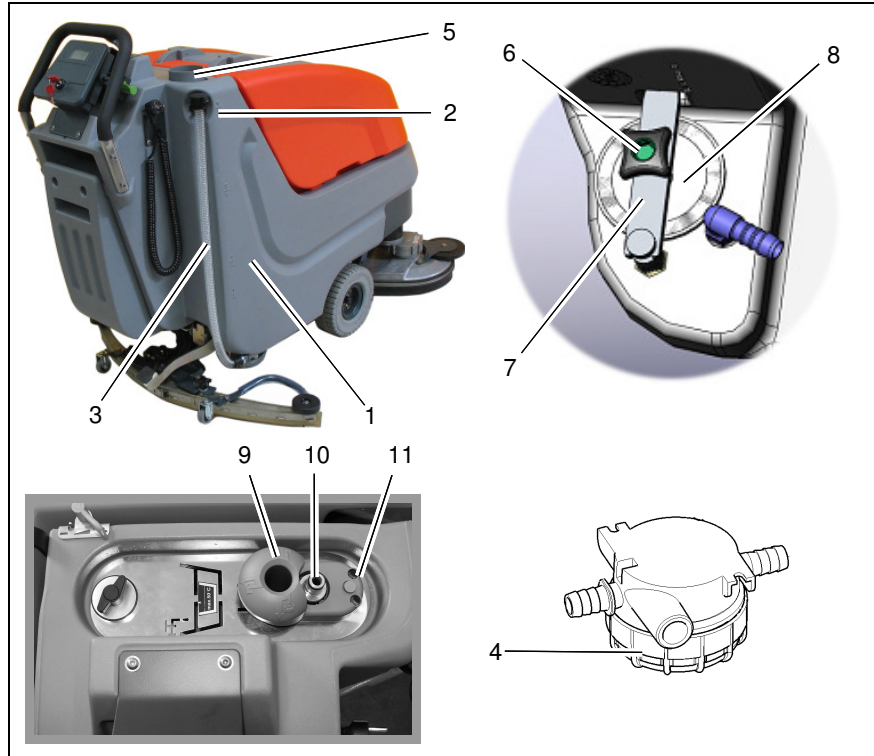

Fig.7

## Maintenance and Care

### 5.5.1 Fill Fresh Water Tank

Fill fresh water tank (Fig. 7/1) before work or as required. Park vehicle on level ground. Open tank lid (Fig. 7/5) and fill tank with fresh water up to the maximum (1/1 marker) (Fig. 7/2).

### 5.5.2 Empty Fresh Water Tank

Park vehicle such that the fill level hose (Fig. 7/3) is located above the drain aperture in the floor. Take fill level hose from holder and remove lid.

### Clean Fresh Water Tank

To open the maintenance hole, loosen the wing bolt (Fig. 7/6), remove the clamping plate (Fig. 7/7) (push upwards and pull out downwards at an angle) and remove the lid (Fig. 7/8) together with seal. After cleaning, close the opening in the reverse working sequence. Check the condition of the seal / sealing surface beforehand. If necessary, replace the seal / clean the sealing surface. Only tighten the wing bolt by hand.

### 5.5.3 Clean Fresh Water Filter

Check fresh water filter (Fig. 7/4) at weekly intervals and clean or replace if required.



Only clean water filter with emptied fresh water tank.

1. Empty fresh water tank (Fig. 7/1), see paragraph 5.5.2.
2. Unscrew filter cap.
3. Remove the filter element from the filter case for cleaning. Replace if required.
4. Re-install filter element and filter cap.

### 5.5.4 Automatic Filling Unit (Option)



In accordance with EN 1717, the filling unit may not be operated without a backflow preventer.

1. Plug on the water connection (Fig. 7/10). Do not open the water supply line at this point!
2. Press the operating button (Fig. 7/9). The indicator knob (Fig. 7/11) projects.
3. Open the water supply line - water flows.
4. The filling unit switches off automatically when the tank is full. The indicator knob (Fig. 7/11) no longer

projects.

5. Close the water supply line and disconnect it. Use a water supply line with a shut-off valve!



The machine can also be filled manually through the hole in the operating button (Fig. 7/9). The transparent hose on the machine serves as a fill level indicator.

## Maintenance and Care

### 5.6 Soiled Water Tank

- 1 Soiled Water Tank
- 2 Drain hose
- 3 Suction filter
- 4 Tank lid



Fig.8

## Maintenance and Care

### 5.6.1 Empty Soiled Water Tank

Clean soiled water tank (Fig. 8/1) at daily intervals, as required or upon acoustic signal (increased suction turbine speed).

1. Take machine to appropriate place for discharge.
2. Park machine such that drain hose attains drain aperture in the floor.
3. Switch off machine.



Observe the legal provisions and the local regulations for disposal of detergents!

4. Take drain hose (Fig. 8/2) from holder and empty soiled water tank completely.

### 5.6.2 Clean Soiled Water Tank

Clean soiled water tank (Fig. 8/1) at daily intervals or as required.

1. Empty soiled water tank, siehe Abschnitt 5.6.1.
2. Open tank lid (Fig. 8/4) of the soiled water tank.
3. Take drain hose (Fig. 8/2) from holder and empty soiled water tank completely.
4. Remove remaining dirt by rinsing with clear water.
5. Rinse drain hose as well.

### 5.6.3 Clean Suction Filter

Check suction filter (Fig. 8/3) for function at daily intervals and clean if required. The suction filter is clipped and can be easily removed.

## Maintenance and Care

### 5.7 Plate brush head

- 1 Pedal for brush head lift-out
- 2 Brush head
- 3 Brush ejectors
- 4 Deflector roller
- 5 Sealing strip

#### 5.7.1 Clean Brushes

Clean brushes of the brush head (Fig. 9/2) at daily intervals or as required.

1. Use pedal (Fig. 9/1) to lift out brush head.
2. Press brush ejectors (Fig. 9/3) down to remove brushes for cleaning.

#### 5.7.2 Change Brushes

Check brushes of the brush head for wearing at weekly intervals. Replace brushes if bristles are worn down to a length of 1.5 cm.

1. Use pedal (Fig. 9/1) to lift out brush head.
2. Press brush ejectors (Fig. 9/3) down to remove old brushes.
3. Push new brush under brush head and use both hands to press it into seating.

#### 5.7.3 Change Deflector Roller

Check deflector roller (Fig. 9/4) at weekly intervals or replace as required.

#### 5.7.4 Change Sealing Strip

Check sealing strip (Fig. 9/5) at weekly intervals or as required. Before doing so, open toggle-type fastener and remove sealing strip. Proceed to mounting in inverse order.



Fig.9



## Maintenance and Care

### 5.8 Squeegee

- 1 Squeegee
- 2 Star-shaped knob
- 3 Eccentric wheel for angle adjustment
- 4 Suction hose
- 5 Fastening device
- 6 Washers for height adjustment

#### 5.8.1 Cleaning the Squeegee

Check the squeegee (Fig. 10/1) daily and clean as necessary. To clean it lift the squeegee out, pull off the suction hose (Fig. 10/4), loosen the two star-shaped knobs (Fig. 10/2) and remove the squeegee.

#### 5.8.2 Changing the Sealing Strips

Check the inner and outer sealing strips on the squeegee (Fig. 10/1) weekly for signs of wear. The sealing strips can be used fourfold by turning them.

1. Lift the squeegee out.
2. Pull off the suction hose, loosen the two star-shaped knobs and remove the squeegee.
3. Unlock the fastening device (Fig. 10/5) and remove the outer sealing strip. Turn the sealing strip or install a new one, as necessary. Change the inner sealing strip in the same way.

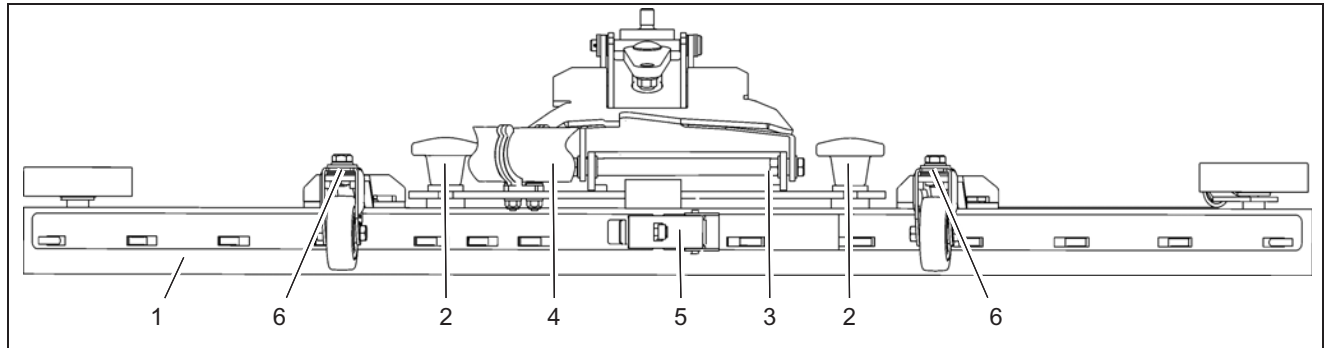

Fig.10

### 5.8.3 Adjusting the Sealing Strips Angle Adjustment

The angle adjustment is the decisive factor in ensuring that the sealing strips on the squeegee lie evenly on the floor.

1. Park the machine on a level surface and lower the squeegee.
2. Loosen the screws on the eccentric wheel (Fig. 11/1) and adjust the squeegee using the eccentric wheel (SW13) so that the ends of the sealing strips still have contact with the floor.

Figure A: Turn the eccentric wheel in the front top position: The clearance between sealing strip and floor is reduced in the centre.

Figure B: Turn the eccentric wheel in the behind top position: The clearance between sealing strip and floor is increased in the centre.

3. Switch the machine on and check the suction pattern. When the machine is in operation, the entire surface of the sealing strips (centre and outer areas) must be applied as evenly as possible.
4. Tighten the screws on the eccentric wheel at 5 lb ft.

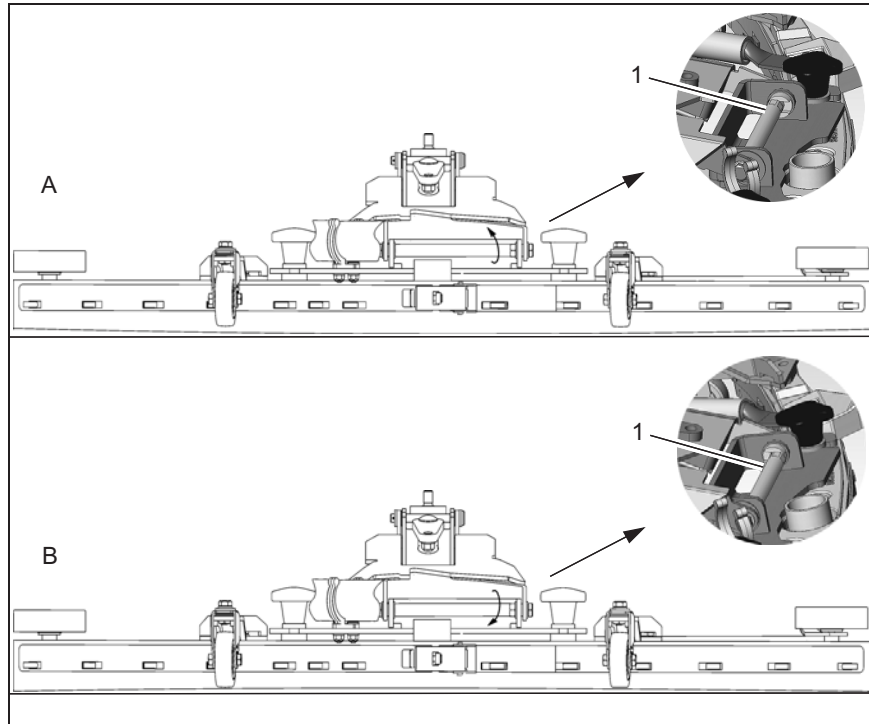

Fig.11

## Maintenance and Care

### Height Adjustment

The height adjustment is set to 3 mm at the factory. If streaks are produced, despite an optimum angle adjustment, the clearance between the rollers and floor must be adjusted by changing the number of washers on the holder.

In the case of very smooth floors, e.g. finished floors, PVC, linoleum, etc.  
Number of washers = 2. This corresponds to a clearance of approx. 2 mm.

In the case of very uneven floors, e.g. poorly laid tiles (water does not run off)  
Number of washers = 4. This corresponds to a clearance of approx. 4 mm.



The Squeegee 110 cm (7569) is equipped with two additional rollers which are adjusted at the factory to a distance of 10 mm to the floor by means of spacers.

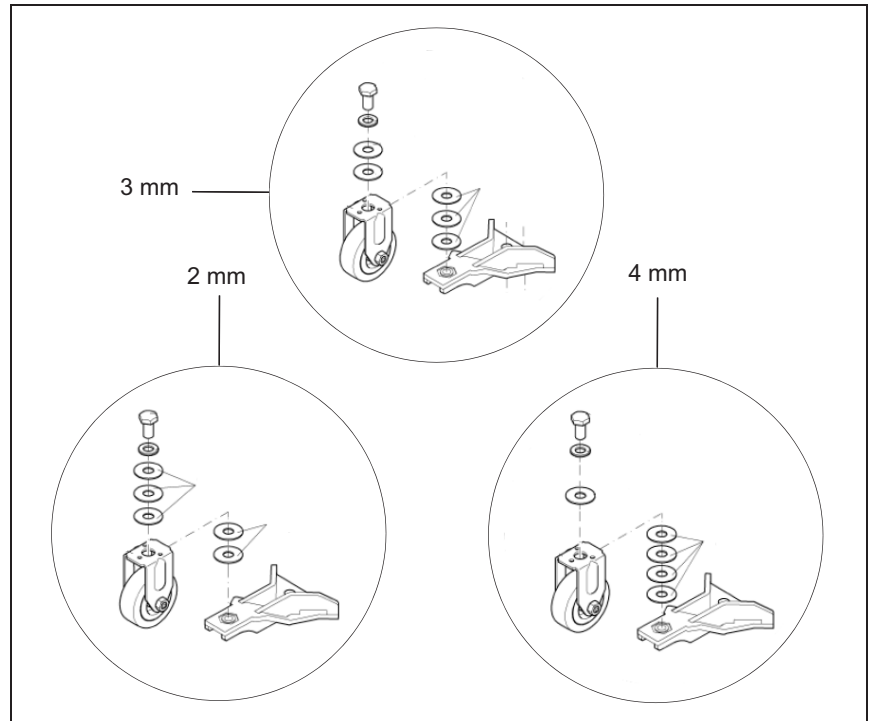

Fig.12

# Scrubmaster B70

## Changes Due to Machine Directive 2006/42/EC



Clean ahead

### Preface

Modified text in paragraph Preface:  
Before using the equipment for the first time, read this original manual thoroughly, act according to the information contained and keep it in a safe place for future reference or subsequent owners.

### Intended use

Modified text in paragraph Intended Use:

Based on the conception, design and construction of the model introduced onto the market by us, the machine complies with the applicable basic safety and health requirements stipulated in the EC Directive (refer to Declaration of Conformity). This declaration is no longer considered valid in the event of modifications to the machine not authorized by us. The manufacturer is not deemed liable for any damage resulting from unauthorized modifications to the machine.

### General safety information

The machine may be used only for operation on plane areas with a maximum inclination of up to 2 %.

### Disposal

New text in Chapter Introduction:  
Render the machine inoperable. It must not represent a potential source of danger for children.

Dispose of the device according to the applicable local regulations. For further information on handling and recycling, please contact your authorized Hako dealer where you purchased the device.

Used batteries with the recycling symbol contain reusable commodities. The heavy metals contained simultaneously represent a serious risk to health and to the environment. Never open batteries or damage them. Never touch, inhale or swallow any material inside batteries. Health hazard! Never allow batteries to pollute the environment. Risk of contaminating the ground and water! In accordance with the symbol with the crossed out bin, these batteries must not be disposed of in domestic waste.

The return and recycling of old batteries must be agreed on with your authorized Hako dealer in accordance with the Battery Law § 6 and § 8 (BattG)

### Noise emission value

The sound pressure level (LpA) (at the ear of the operator) measured according to DIN IEC 60335-2-72 under normal working conditions: 67 dB (A)

Measurement inaccuracy (KpA):

1,6 dB (A)

Sound power level (LwAd) measured according to DIN EN 60335-2-72 under maximum working conditions:

82 dB (A)

### Vibration

The weighted effective value of acceleration, measured in accordance with ISO 5349-1, to which the upper parts of the body (hand-arm) are exposed under normal working conditions:

< 2,5 m/s<sup>2</sup>

The weighted effective value of acceleration, measured in accordance with ISO 2631-1, to which the upper parts of the body (feet-seat) are exposed under normal working conditions:

< 0,5 m/s<sup>2</sup>

## EC Declaration of Conformity (corresponds to EC Directive 2006/42/EC)

**Hako GmbH**  
**Hamburger Straße 209-239**  
**D-23843 Bad Oldesloe**

declares that the products

**Scrubmaster B70, Typ 7061**

to which this declaration relates, conform to the relevant provisions of the safety and health requirements stipulated in EC Directive 2006/42/EC and is in accordance with 2004/108/EC.

Reference was made to the following standards and/or norms and/or technical specifications to ensure proper implementation of the safety and health requirements in the EC Directive:

**EN 60335-2-72**  
**EN 55012**  
**EN 61000-6-2**

Bad Oldesloe, 22.04.2014



Dr. Rainer Bavendiek  
Director R&D

Name of the authorized person who compiles technical documents for Hako:

Ludger Lüttel



# Spitzentechnik für eine saubere und schönere Umwelt

Advanced Technology for a Cleaner, Better Environment



Hako GmbH • Hamburger Str. 209-239 • D-23843 Bad Oldesloe  
Tel. +49 4531 806-0 • Fax +49 4531 806-338